

Tools required :
- 6mm hex key (included)

CALERA SIDE TABLE 22 x 22 in

ASSEMBLY INSTRUCTIONS

- 1 Use the carton as a protective work surface by flattening out the sides and ends.

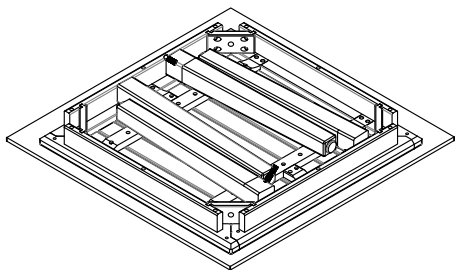

- 2 Secure the legs to the table top using the M8x60mm bolts, spring washer and flat washer. Ensure the flat and spring washers are in the correct position. Flat washer should be nearest to the frame, while spring washer should be nearest to the M8x60mm bolts.

Important!
Do not use power tools on this assembly.
Use the supplied manual hex key.

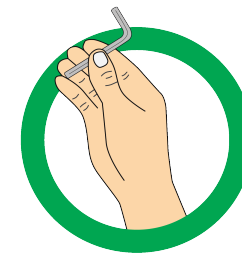
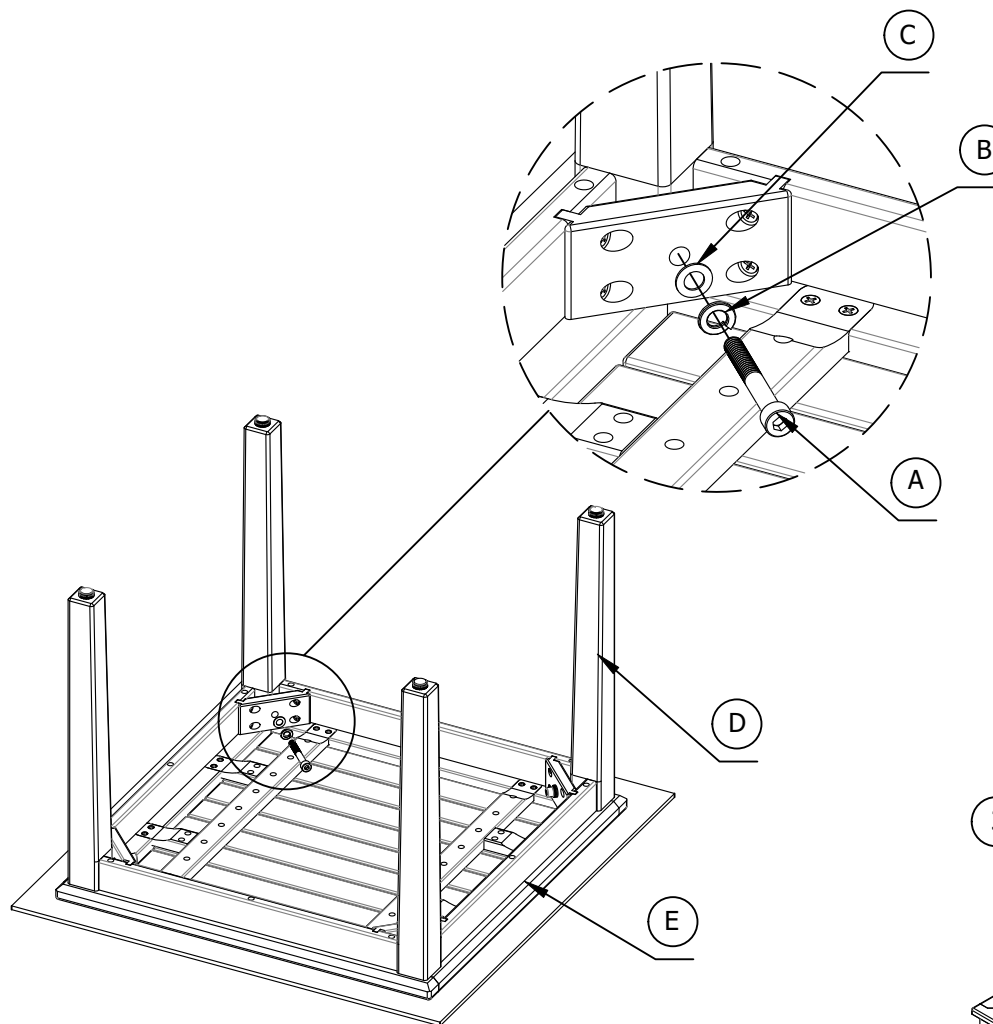

- 3 Turn the table right-side-up.

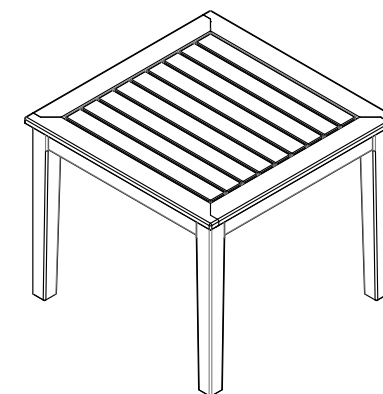

A BOLT M8x60mm

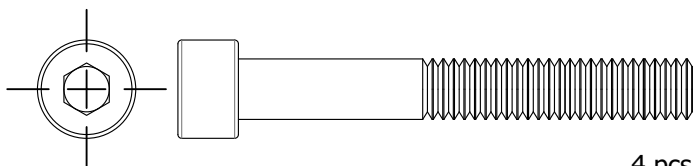

4 pcs

B SPRING WASHER M8

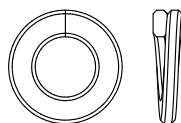

4 pcs

C FLAT WASHER M8

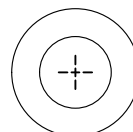

4 pcs

D LEGS ASSEMBLY

E TABLE TOP ASSEMBLY