

Tools required :
- 4mm hex key (included)
- 5mm hex key (included)

JOHNY ROUND DINING TABLE Ø71 in.

ASSEMBLY INSTRUCTIONS



Important !!

Do not use power tools on this assembly.
Use the supplied manual hex key.

- 1 Secure a plate connector to each leg using the supplied M6x25 mm bolts.
!! Carefully check the orientation of the plate connections to ensure they match the drawing below.

- 2 Loosely secure the legs to the leg connector tube using the supplied M8x20mm bolts, flat washers and spring washers. Ensure the flat and spring washer are in the correct position. Flat washer should be nearest to the leg connector tube, while spring washer should be nearest the bolt.
- Do not tighten the bolts fully!

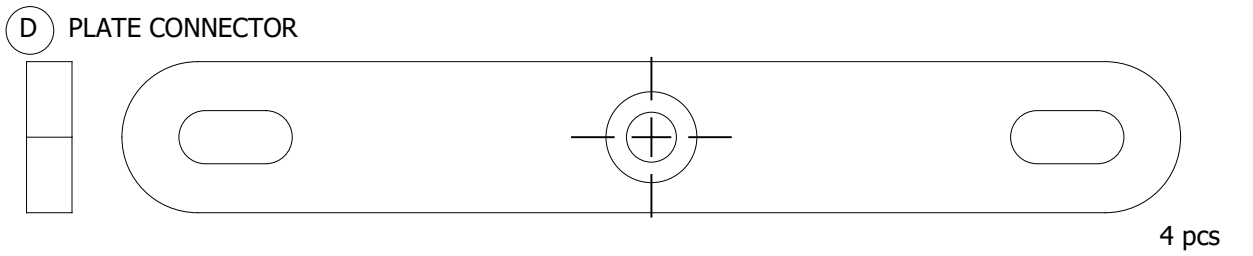
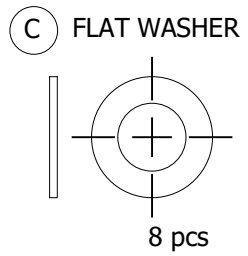
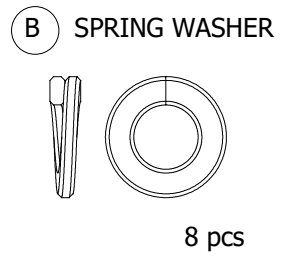
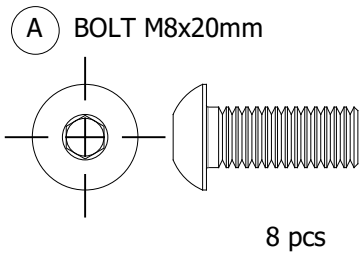
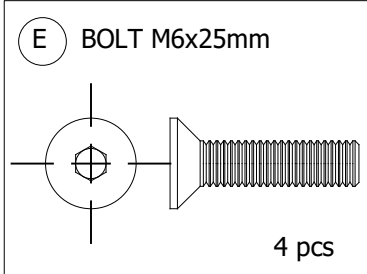
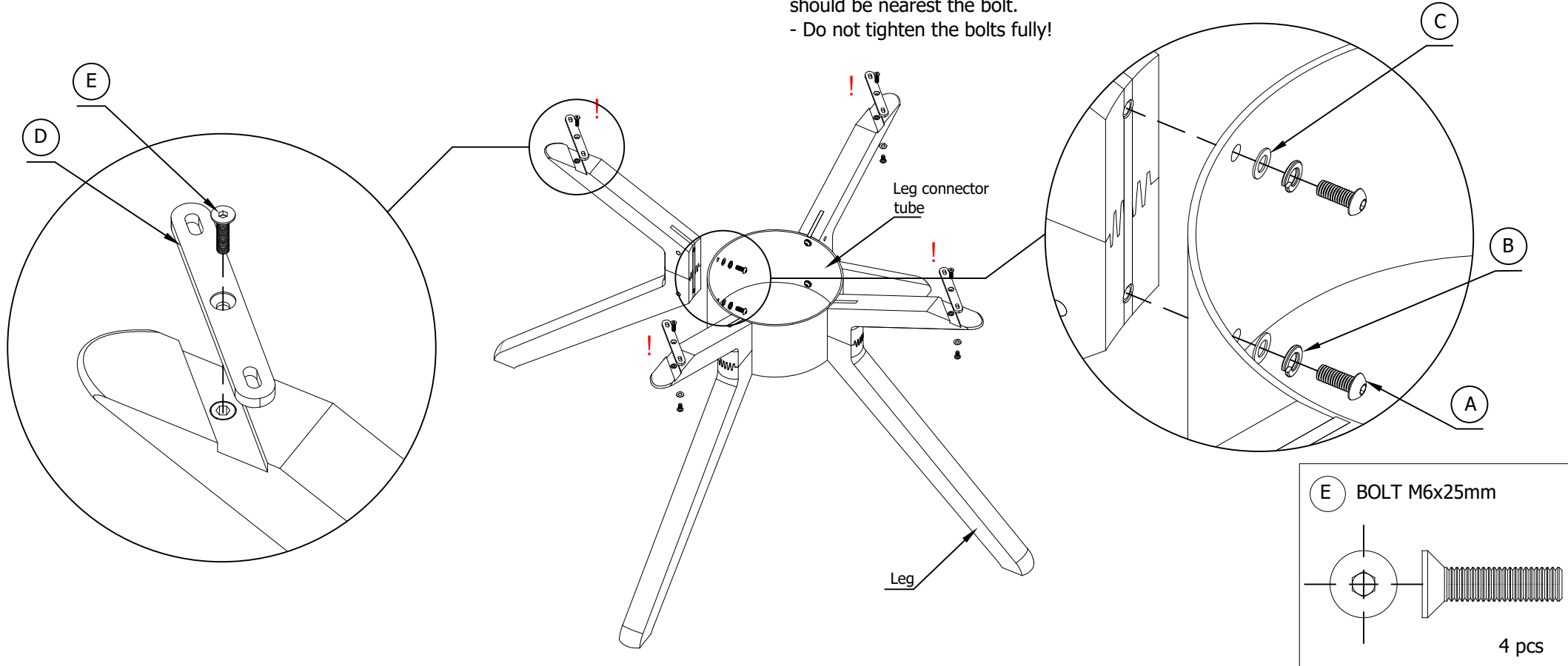

JOHNY ROUND DINING TABLE Ø71 in.

ASSEMBLY INSTRUCTIONS

- 3 a. Loosely secure the frame assembly to the table top using the supplied M6x20mm bolts and plastic washers.
- b. Tighten the 8 pcs M8x20mm bolts fully, followed by tightening the 8 pcs M6x20mm bolts.

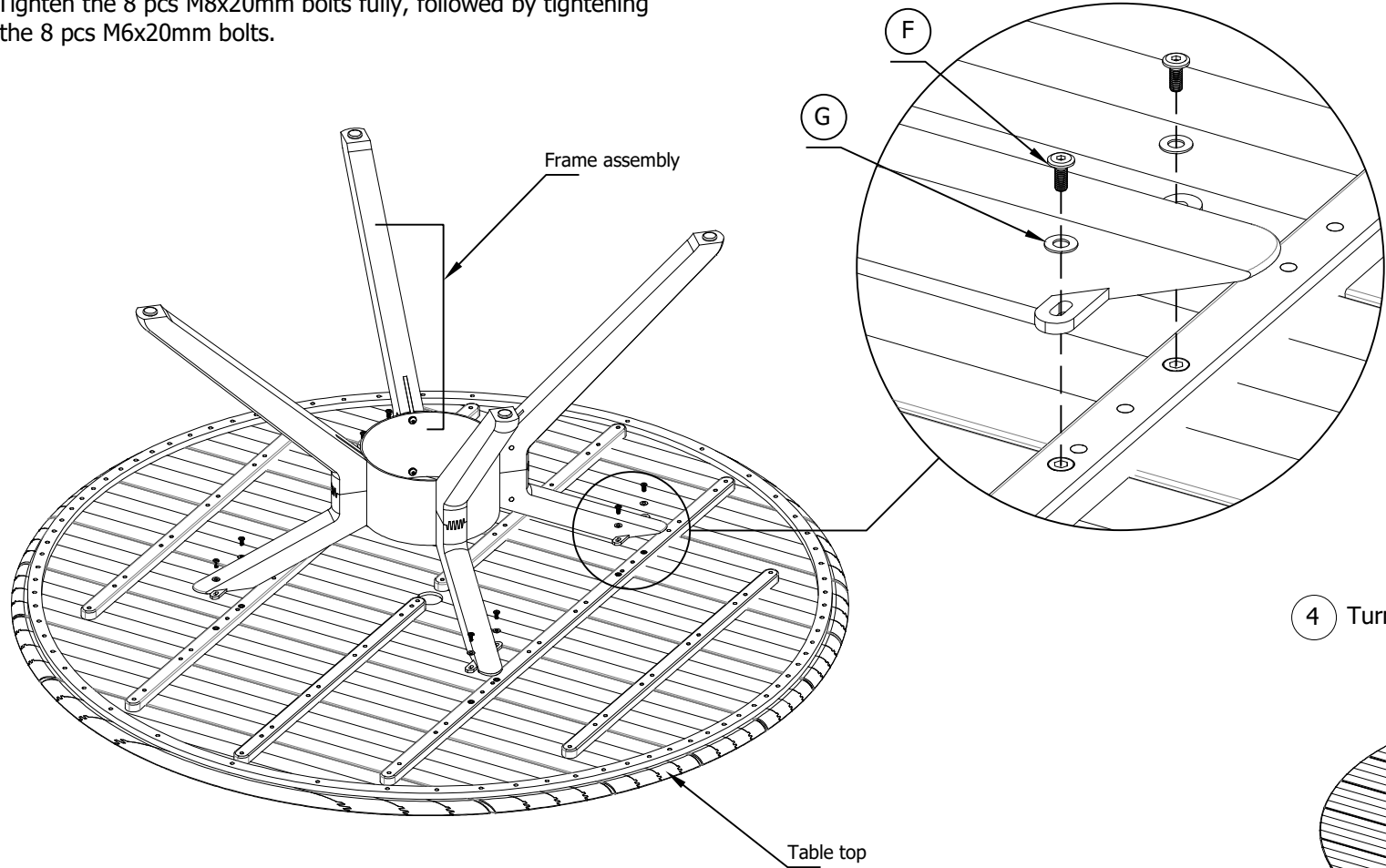

- 4 Turn the table right-side-up.

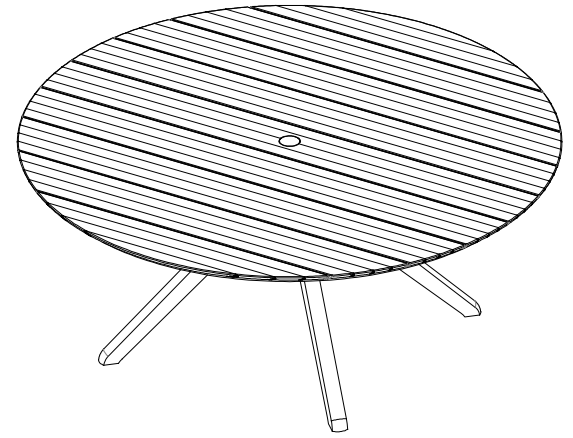

F BOLT M6x20mm	G PLASTIC WASHER
8 pcs	8 pcs